

## Team Strike Evo



### Storie collegate

**M3 Mobili**, Ciudad de México, Messico (2023)

## Team Strike Evo Ejecutivo, con estructura blanca

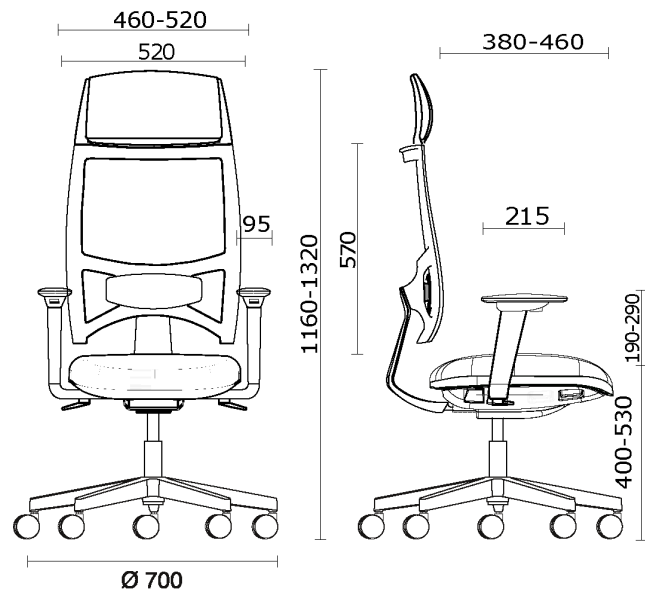

## Materiali e rivestimenti

### Respaldo en malla

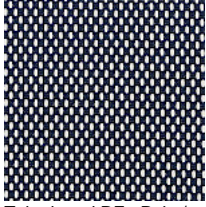

Tela de red RF - Polo / FIDiVi Service  
Colori disponibili: 5

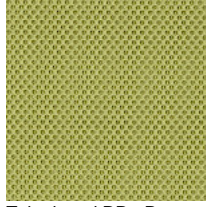

Tela de red RR - Runner / Gabriel  
Colori disponibili: 10

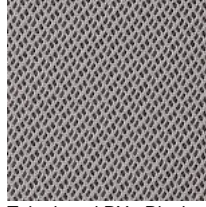

Tela de red RY - Rhythm / Gabriel  
Colori disponibili: 6

### Tapizado del asiento con respaldo en malla



Tejido recubierto NX  
Colori disponibili: 11



Tejido recubierto SC - Secret / Flukso  
Colori disponibili: 10

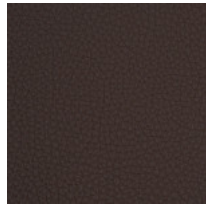

Tejido recubierto NX  
Colori disponibili: 1



Cuero SX - Box Land / Dani  
Colori disponibili: 12



Tela AL - Alba / FIDiVi  
Colori disponibili: 10



Tela BN - Bondai / FIDiVi  
Colori disponibili: 10



Tela AB - Xtreme Plus / Camira  
Colori disponibili: 10

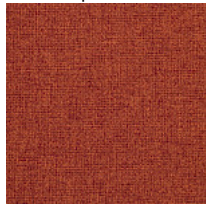

Tela ME - Medley / Gabriel  
Colori disponibili: 15

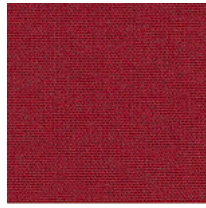

Tela MF - Main Line Flax / Camira  
Colori disponibili: 10

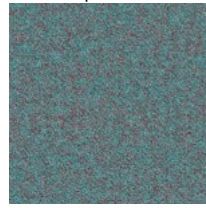

Tela SY - Sinergy / Camira  
Colori disponibili: 10

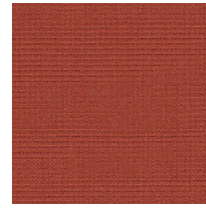

Tela CS - Crisp / Gabriel  
Colori disponibili: 10



Tela RM - Remix 3 / Kvadrat  
Colori disponibili: 10



Tela CH - Chili / Gabriel  
Colori disponibili: 10

### Asiento y respaldo con membrana técnica



Tela BN - Bondai / FIDiVi  
Colori disponibili: 10

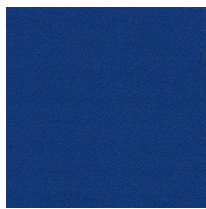

Tela AB - Xtreme Plus / Camira  
Colori disponibili: 10

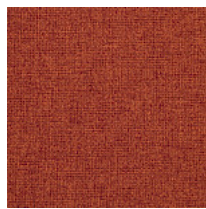

Tela ME - Medley / Gabriel  
Colori disponibili: 15



Tela CH - Chili / Gabriel  
Colori disponibili: 10

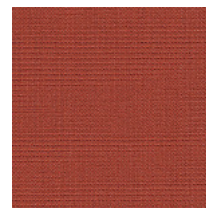

Tela CS - Crisp / Gabriel  
Colori disponibili: 10



Tela RM - Remix 3 / Kvadrat  
Colori disponibili: 10

**Questo prodotto è garantito 5 anni.** Sitland Spa si riserva di apportare modifiche e/o migliorie di carattere tecnico ed estetico ai propri modelli e prodotti in qualsiasi momento e senza preavviso. Le foto e i colori visualizzati sono puramente indicativi e possono variare rispetto alla realtà. Per maggiori informazioni si prega di contattare il nostro Servizio Clienti [service@sitland.com](mailto:service@sitland.com)