

Team Strike Evo



Storie collegate

M3 Mobili, Ciudad de México, Messico (2023)

Team Strike Evo Ejecutivo, estructura negra

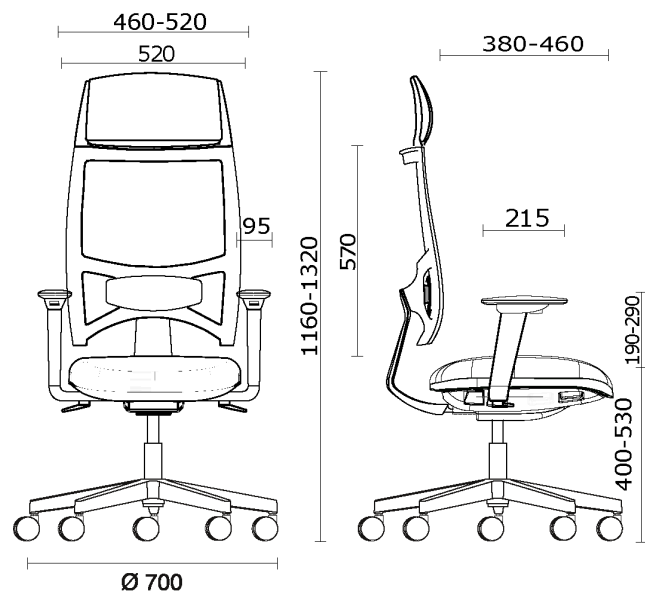

Materiali e rivestimenti

Respaldo en malla

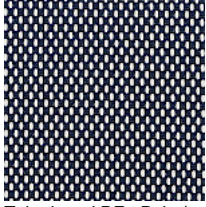

Tela de red RF - Polo /
FIDiVi Service
Colori disponibili: 5

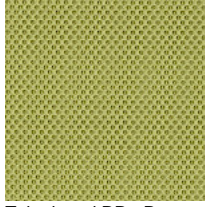

Tela de red RR - Runner
/ Gabriel
Colori disponibili: 10

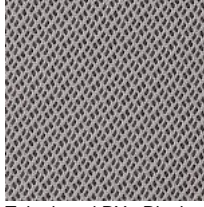

Tela de red RY - Rhythm
/ Gabriel
Colori disponibili: 6

Tapizado del asiento con respaldo en malla



Tejido recubierto NX
Colori disponibili: 11



Tejido recubierto SC -
Secret / Flukso
Colori disponibili: 10

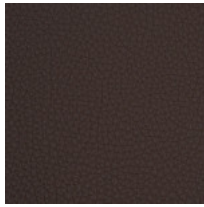

Tejido recubierto NX
Colori disponibili: 1

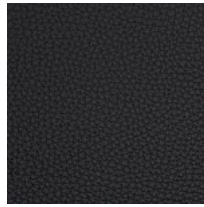

Cuero SX - Box Land /
Dani
Colori disponibili: 12



Tela AL - Alba / FiDiVi
Colori disponibili: 10



Tela BN - Bondai /
FiDiVi
Colori disponibili: 10



Tela AB - Xtreme Plus /
Camira
Colori disponibili: 10



Tela ME - Medley /
Gabriel
Colori disponibili: 15

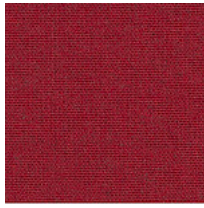

Tela MF - Main Line Flax
/ Camira
Colori disponibili: 10

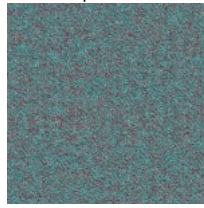

Tela SY - Sinergy /
Camira
Colori disponibili: 10

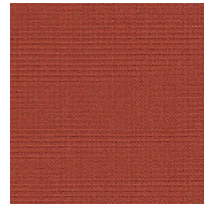

Tela CS - Crisp / Gabriel
Colori disponibili: 10



Tela RM - Remix 3 /
Kvadrat
Colori disponibili: 10



Tela CH - Chili / Gabriel
Colori disponibili: 10

Asiento y respaldo con membrana técnica



Tela BN - Bondai /
FiDiVi
Colori disponibili: 10

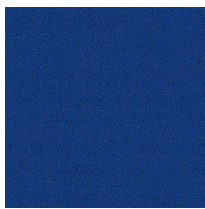

Tela AB - Xtreme Plus /
Camira
Colori disponibili: 10



Tela ME - Medley /
Gabriel
Colori disponibili: 15

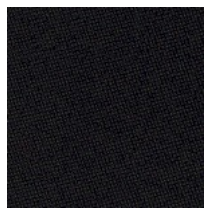

Tela CH - Chili / Gabriel
Colori disponibili: 10



Tela CS - Crisp / Gabriel
Colori disponibili: 10



Tela RM - Remix 3 /
Kvadrat
Colori disponibili: 10

Questo prodotto è garantito 5 anni. Sitland Spa si riserva di apportare modifiche e/o migliorie di carattere tecnico ed estetico ai propri modelli e prodotti in qualsiasi momento e senza preavviso. Le foto e i colori visualizzati sono puramente indicativi e possono variare rispetto alla realtà. Per maggiori informazioni si prega di contattare il nostro Servizio Clienti service@sitland.com