

Milos Lounge



Storie collegate

Refin Studio, Milano, Italia (2023)

Your Workspace Showroom, Clerkenwell, Regno Unito (2023)

Al Khayat Avenue Gallery, Dubai, Emirati Arabi Uniti (2023)

Eco Park Area Lounge, Aberdeen, Regno Unito (2023)

Poltrona su base in legno

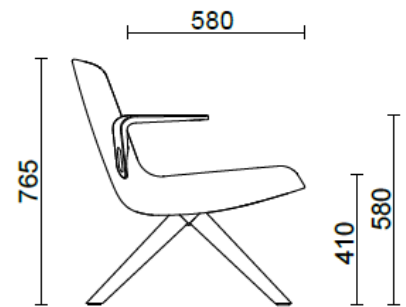
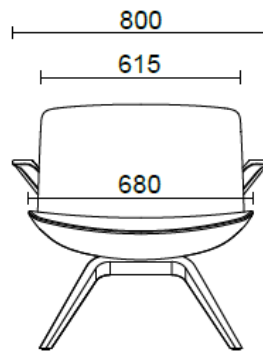
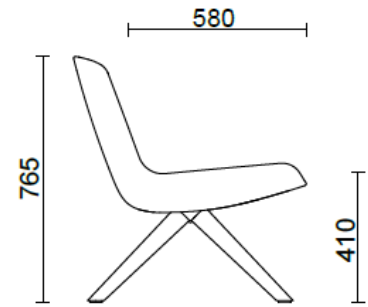
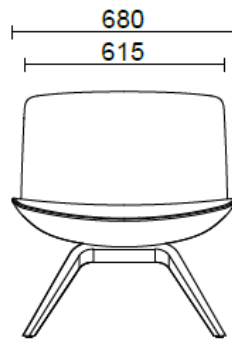

Materiali e rivestimenti

Rivestimento



Tessuto spalmato NX
Colori disponibili: 11



Tessuto spalmato SC - Secret / Flukso
Colori disponibili: 10



Tessuto spalmato NX
Colori disponibili: 1

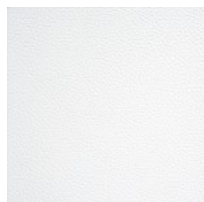

Pelle PA - Panama / Dani
Colori disponibili: 10



Tessuto ME - Medley / Gabriel
Colori disponibili: 15



Tessuto MF - Main Line Flax / Camira
Colori disponibili: 10



Tessuto MW - Main Line Twist / Camira
Colori disponibili: 7



Tessuto CS - Crisp / Gabriel
Colori disponibili: 10

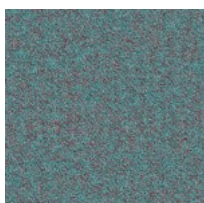

Tessuto SY - Sinergy / Camira
Colori disponibili: 10



Tessuto FT - Foster / Vescom
Colori disponibili: 7

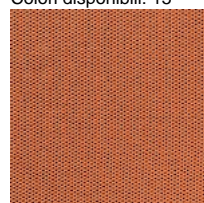

Tessuto WI - Wilson / Vescom
Colori disponibili: 10

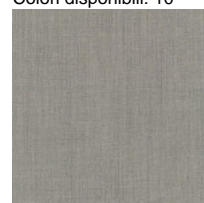

Tessuto RM - Remix 3 / Kvadrat
Colori disponibili: 10

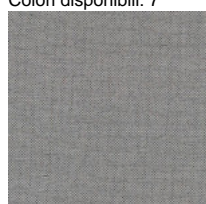

Tessuto RW - Re-wool / Kvadrat
Colori disponibili: 4



Tessuto HE - Hero 2 / Kvadrat
Colori disponibili: 6



Tessuto FD - Fiord 2 / Kvadrat
Colori disponibili: 7



Tessuto S1 - Steelcut 3 / Kvadrat
Colori disponibili: 13

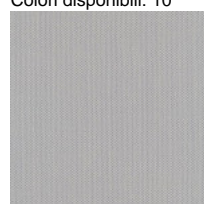

Tessuto SE - Steelcut Trio 3 / Kvadrat
Colori disponibili: 15

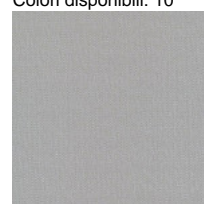

Tessuto S4 - Steelcut Quartet / Kvadrat
Colori disponibili: 5

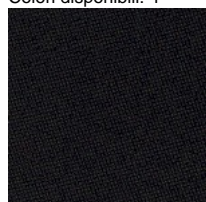

Tessuto CH - Chili / Gabriel
Colori disponibili: 10

Questo prodotto è garantito 5 anni. Sitland si riserva di apportare modifiche e/o migliorie di carattere tecnico ed estetico ai propri modelli e prodotti in qualsiasi momento e senza preavviso. Le foto e i colori visualizzati sono puramente indicativi e possono variare rispetto alla realtà. Per maggiori informazioni si prega di contattare il nostro Servizio Clienti service@sitland.com